



Specification sheet

PVE RD 430

Vibro Hammer

English

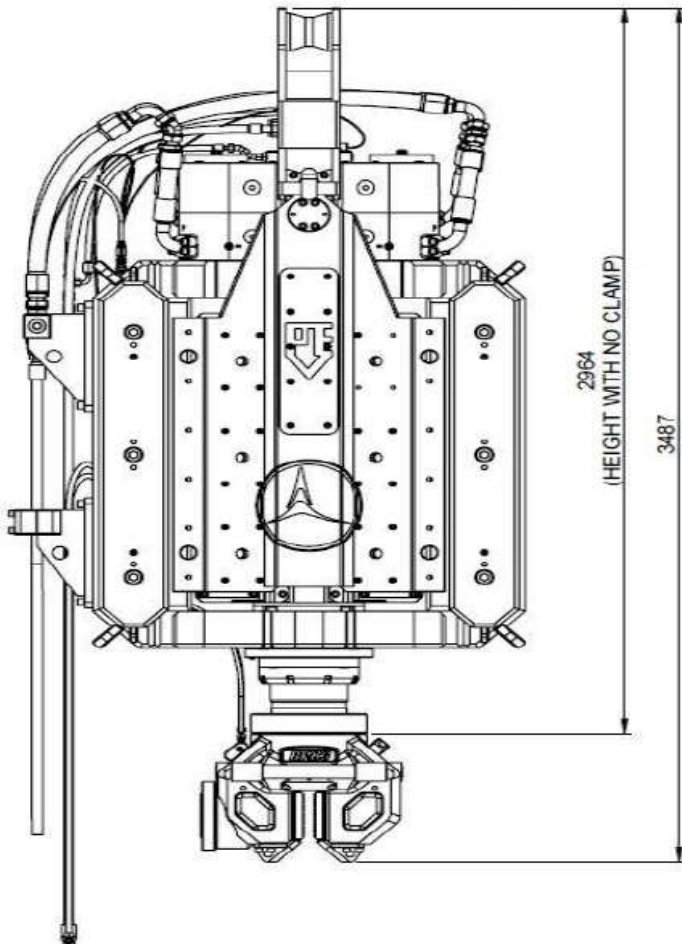
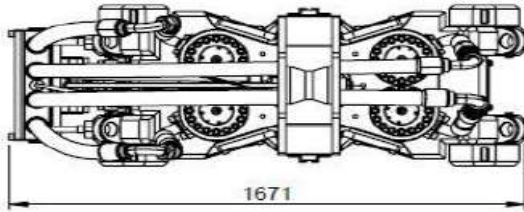

Specifications :

PVE RD 430

| | | | |
|-------------------------------|-------------|----------------------------|---------|
| Hydraulic power | 430 kW | Clamps: | |
| Frequency range | 60 - 160 Hz | | RPC3 |
| Max amplitude (in resonance) | 3 - 6 mm | Transport weight per piece | 470 kg |
| Max. static line-pull | 400 kN | Clamp pressure | 690 bar |
| Max. pull-down | 400 kN | | |
| Max. operating pressure | 350 bar | | |
| Max. oil flow | 550 l/min | | |
| Total weight (excl. clamp) | 5328 kg | | |
| Total weight (including RPC3) | 6649 kg | Powerpack: | |
| Total weight (including RPC2) | N/A kg | Model | 600RTI |